

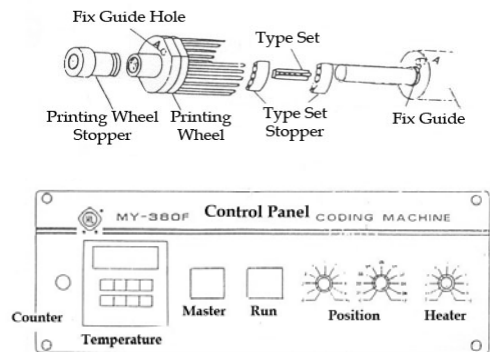

MY-380F DRY INK CODING MACHINE

MY-380F is a special kind of label printing equipment. It is suitable for printing labels on the surface of paper, non-porous plastic film, & aluminum foil. It uses a cantilever type mechanism, which is light and precise. Its horizontal printing position is controlled by an electronic device that can be easily adjusted as needed. The object is selected by the machine's special sensor. The machine also has a unique stepping clutch and produces very little noise. It is equipped with a fast dry-ink roller with clear characters. Moreover, it uses advanced dry-ink rollers for printing, which has several color choices such as black, red, yellow, and blue. The dry ink print will print clearly and is easily changeable.



Sample of typeset printed on a 5" x 5" plastic bag. (actual size)

Typeset includes:

- 12 pieces of #0, 1
- 10 pieces of #2
- 6 pieces of #3-9
- 2 pieces of M, F, D
- 2 pieces of E, X, P

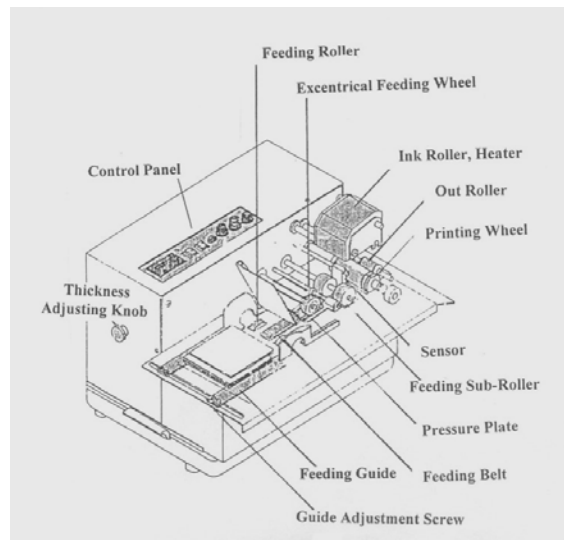

Specifications

Power	110V	Printing Lines	5 lines, max., 10 letters/line
Watts	180w	Print Position	within 24" (width) x 10" (length)
Weight	51 lbs.	Type Size	2mm, 2.5mm, 3 mm
Dimensions (L x W x H)	18" x 13.5" x 10"	Object Size Length	2" to 19"
Speed	300 pcs./min.	Width	1" to 11"